

The Flame of Desire



GAS & WOOD
HEARTH SYSTEMS

BAY VISTA DIRECT VENT GAS FIREPLACE

BAY VISTA™ DIRECT VENT GAS FIREPLACE

Distinctively designed with state-of-the-art technology

Standard Features

- Distinctive one piece formed ceramic glass
- Heater rated
- Piezo ignition for electricity-free operation
- Safety shut-off switch
- 5 year limited warranty
- Concealed control panel
- Thermostatically controlled variable speed fan
- Four realistic ceramic fibre logs
- Glowing embers
- Gold plated trim
- Variable flame control

Installation Versatility

- Ground level and above
- Basement installations, below grade
- Bedroom installations
- Condominiums, apartments, houses
- Installs through the wall, vents up to 13 ft. horizontally
- Vertical installation through the roof, up to 30 ft.

Options

- Upper and lower gold door trim
- Grille sets available in black metallic, baked enamel colors or gold plated
- Wall thermostat
- Hand held remote control
- Faceplate available in black metallic, baked enamel colors or gold plated

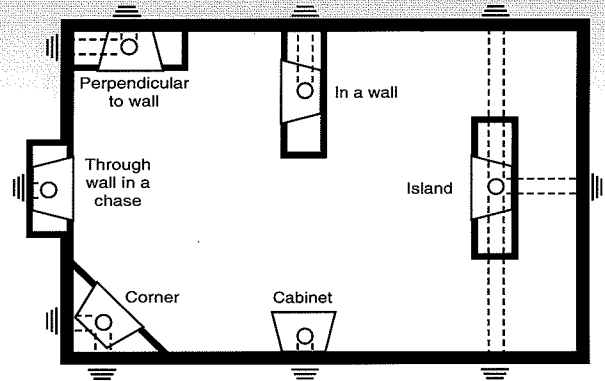

Specifications

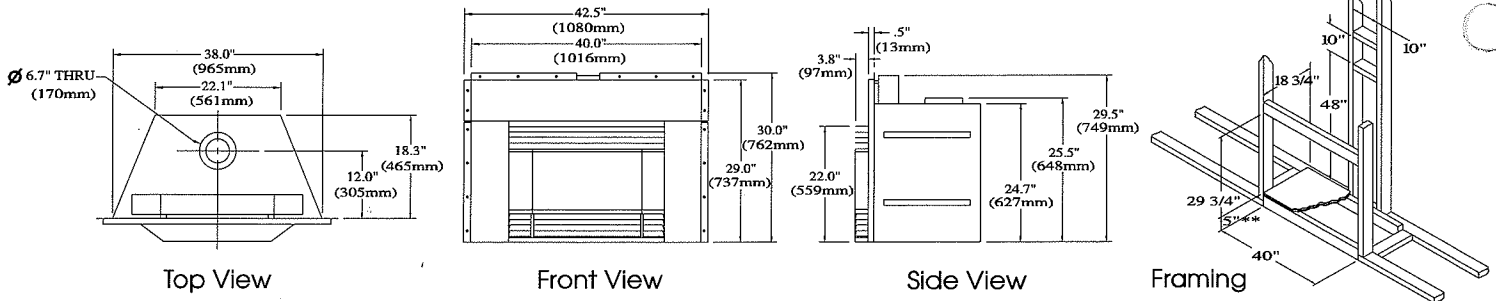

MODEL	Maximum BTU Input	Input (low)	Efficiency* (steady state)	AFUE Efficiency*	HEIGHT**		FRONT WIDTH		BACK WIDTH		DEPTH		MANTLE HEIGHT***		
					Actual	Framing	Actual	Framing	Actual	Framing	Actual	Framing	4"	7 1/4"	10"
NATURAL GAS	40,000/hr	27,000 BTU/hr 879 kwh	73.8%	69.2%	29.5"	29.75"	38.0"	40.0"	22.1"	23.0"	18.3"	18.75"	12"	18"	28"
PROPANE	40,000/hr	33,000 BTU/hr 967 kwh	79.5%	75.0%	(749mm)	(756mm)	(965mm)	(1016mm)	(561mm)	(584mm)	(465mm)	(476mm)	(305mm)	(457mm)	(711mm)

NOTES: * fan on
 ** allow an additional 1" - 5" in height for flooring options (See manual for further details).
 *** from top louvre to mantile (distance between inside of posts 43").

No combustibles are permitted within the enclosure from the floor of the unit up to 72" (1830mm) above. Specifications are subject to change, as Osburn strives constantly to improve its products, to assure you of a top quality product that will function safely and efficiently for years to come. A local building or fire official should be consulted concerning restrictions and installation inspection requirements.

PLEASE read Owner's Manual PRIOR to framing and installing unit for further product specifications.

ISO 9002

WARNOCK HERSEY



GAS & WOOD
HEARTH SYSTEMS

OSBURN MANUFACTURING
555 ARDERSIER ROAD, VICTORIA, B.C., V8Z 1C8, CANADA

AUTHORIZED DEALER

WARRANTY:

All Osburn products carry a five year limited warranty on workmanship and materials. Consult Bay Vista Direct Vent Gas Fireplace owner's manual for further details.

TESTING STANDARDS

CAN/CGA 2.19 M81, CAN/CGA 2.17 M91
CGA INT. REG.#41 & #55, ANSI Z21.44B-1993



PRINTED IN CANADA
08/96



OSBURN BAY VISTA

DIRECT VENT

Built-In Direct Vent Gas Fireplace Installation and Operation Instructions

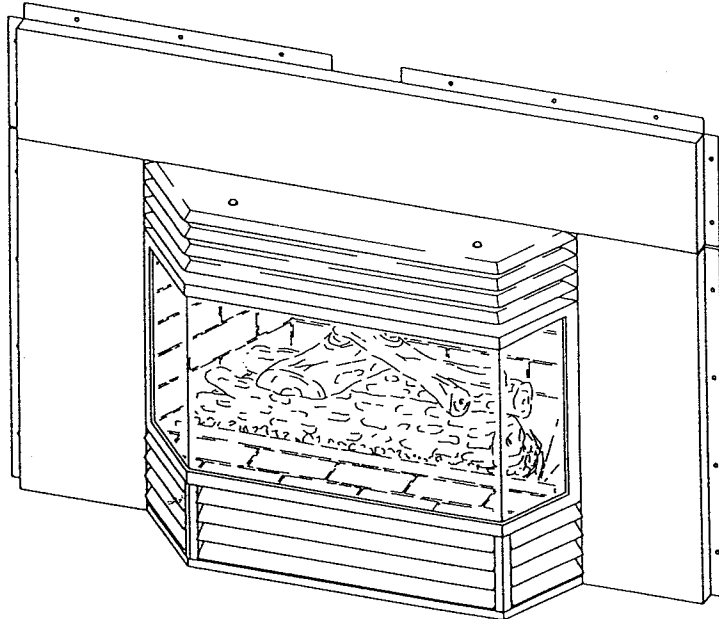

The Flame of Desire

WARNING: If the information in this manual is not followed exactly, a fire or explosion may result causing property damage, personal injury or loss of life.

Do not store or use gasoline or other flammable vapors and liquids in the vicinity of this or any other appliance.

WHAT TO DO IF YOU SMELL GAS

- Do not try to light any appliance.
- Do not touch any electrical switch; do not use any phone in your building.
- Immediately call your gas supplier from a neighbor's phone. Follow the gas supplier's instructions.
- If you cannot reach your gas supplier, call the fire department.

Installation and service must be performed by a qualified installer, service agency or the gas supplier.

WARNING

Improper installation, service, adjustment, alteration, or maintenance can cause injury or property damage. Refer to this manual. For assistance or additional information, consult a qualified installer, service agency, or the gas supplier.

Please read this manual before installing or using this appliance. Retain this manual for future reference.

Patents Pending

Made in Canada



CZ060

04/14/97

1.0 INTRODUCTION

1.1 SPECIFICATIONS

TABLE 1 SPECIFICATIONS

ITEM	NATURAL GAS (NG)	PROPANE (LPG)
INPUT:	High	40,000 Btu/hr (42.2 MJ/hr)
	Low	28,000 Btu/hr (29.5 MJ/hr)
Flue Loss Efficiency: Fan off		72.5%
	Fan on	73.8%
AFUE Efficiency: Fan On		71.8%
	Fan Off	70.5%
MANIFOLD PRESSURE:	3.5" w.c. (0.9 kPa)	10.0" w.c. (2.5 kPa)
GAS INLET SUPPLY PRESSURE:	Minimum: 5.0" w.c. (1.2 kPa)	Minimum: 11.0" w.c. (2.7 kPa)
	Normal: 7.0" w.c. (1.7 kPa)	Normal: 13.3" w.c. (3.3 kPa)
	Maximum: 13.5" w.c. (3.4 kPa)	Maximum: 13.5" w.c. (3.4 kPa)
ORIFICE SIZE:	31 DMS (.120") (3.06mm)	47 DMS (.078") (2.00mm)
CONTROL VALVE:	Sit 820 Nova	
SHIPPING WEIGHT:	145 lb. (66 kg)	
CHIMNEY:	Simpson Duravent Model DV-GS	
FAN:	Variable Speed 120 CFM	

NOTE: The efficiency rating of the appliance is a product thermal efficiency rating determined under continuous operating conditions and was determined independently of any installed system.

- OPTIONS:**
- Gold & color grille assemblies
 - Gold and color faceplates
 - Remote Control
 - Thermostat
 - Top & bottom gold door trim

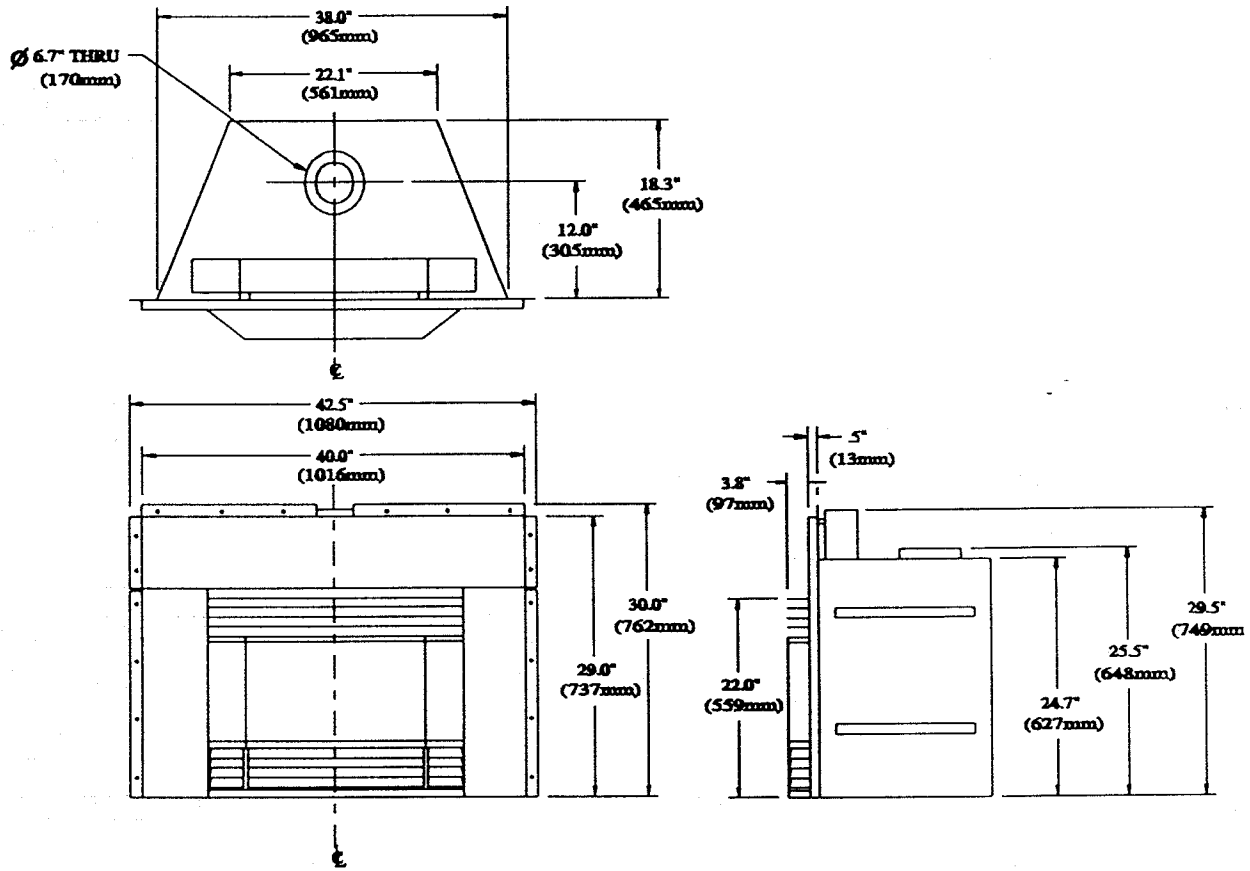

Figure 1

INSTALLATION CODES

Installation must conform to local codes. In the absence of local codes, installation must conform to the National Fuel Gas Code, ANSI Z233.1 1988, (in the U.S.), or with the current installation code CAN/CGA B149.1-M86 (in Canada). In Australia, the Australian Gas Association installation code for gas burning heaters and equipment must be used. The appliance, when installed, must be electrically grounded in accordance with local codes or, in the absence of local codes, with the National Electric code ANSI/NFPA No. 70-1990 (in the U.S.) or with the current CSA C22.1 Canadian Electrical code (in Canada), or in other countries with the appropriate national code.

1.2 FEATURES

Ignition system:

Standing pilot ignition system with thermopile and thermocouple flame detection and piezo igniter.

Gas control:

Gas control valve type:

Automatic millivolt powered combination gas control valve with optional remote on/off switch, optional wall thermostat, and/or optional remote control. The gas valve does not require electricity.

Fan control:

Variable Speed Control:

The knob controls fan speed in connection with a heat sensitive switch which turns on when the heater reaches operating temperature. Turning the knob counterclockwise ← turns it to the "OFF" position.

Safety controls:

A safety switch will shut the system down in the event of loss of pilot flame.

Outside combustion air supply:

The combustion air supply is obtained entirely from outside the heated living space by the intake of outside air through the outer portion of the 6 5/8" coaxial double wall vent pipe. Exhaust gases pass through the inner portion of 4" pipe.

1.3 INTENDED USE

This appliance is intended to be used as a heater, when installed as a built-in fireplace, according to minimum requirements as described in detail in the installation instructions. This appliance is suitable for installation in bedrooms where the maximum input is within 50 cubic feet of room volume per 1000 BTU/hr, (i.e. 2000 cubic feet). The appliance is also suitable for retrofit into mobile homes.

1.4 GENERAL SAFETY

The appliance must be properly connected to a venting system in accordance with local codes. This unit must not be connected to a chimney or flue serving any other appliance.

WARNING: Operation of this fireplace when not connected to a properly installed and maintained venting system, may result in carbon monoxide poisoning.

Installation and repair should be done by a qualified service person. The appliance should be inspected before use and at least annually by a professional service technician. Provide adequate clearances around air openings and allow accessibility clearance for servicing and proper operation.

2.0 OPERATION

2.1 OPERATION SAFETY

Inspect the appliance before use. Always keep the appliance area clear and free from combustible materials, gasoline and other flammable vapors and liquids. Never obstruct the flow of ventilation air. Keep the front of the appliance clear of all obstacles and foreign materials. Never obstruct or modify the air inlet/outlet grilles of the fireplace in any manner.

CAUTION: Children and adults should be alerted to the hazards of high surface temperature and should stay away to avoid burns or contact with hot surfaces. Young children should be carefully supervised when they are in the same room as the heater. Clothing or other flammable material should not be placed on or near the unit.

The glass door and louvers must be properly installed prior to operation. Never operate the unit with the glass door off or broken since this may cause dangerous indoor air pollution. This unit is not for use with solid fuel. Do not substitute any parts or materials. Do not abuse the glass door.

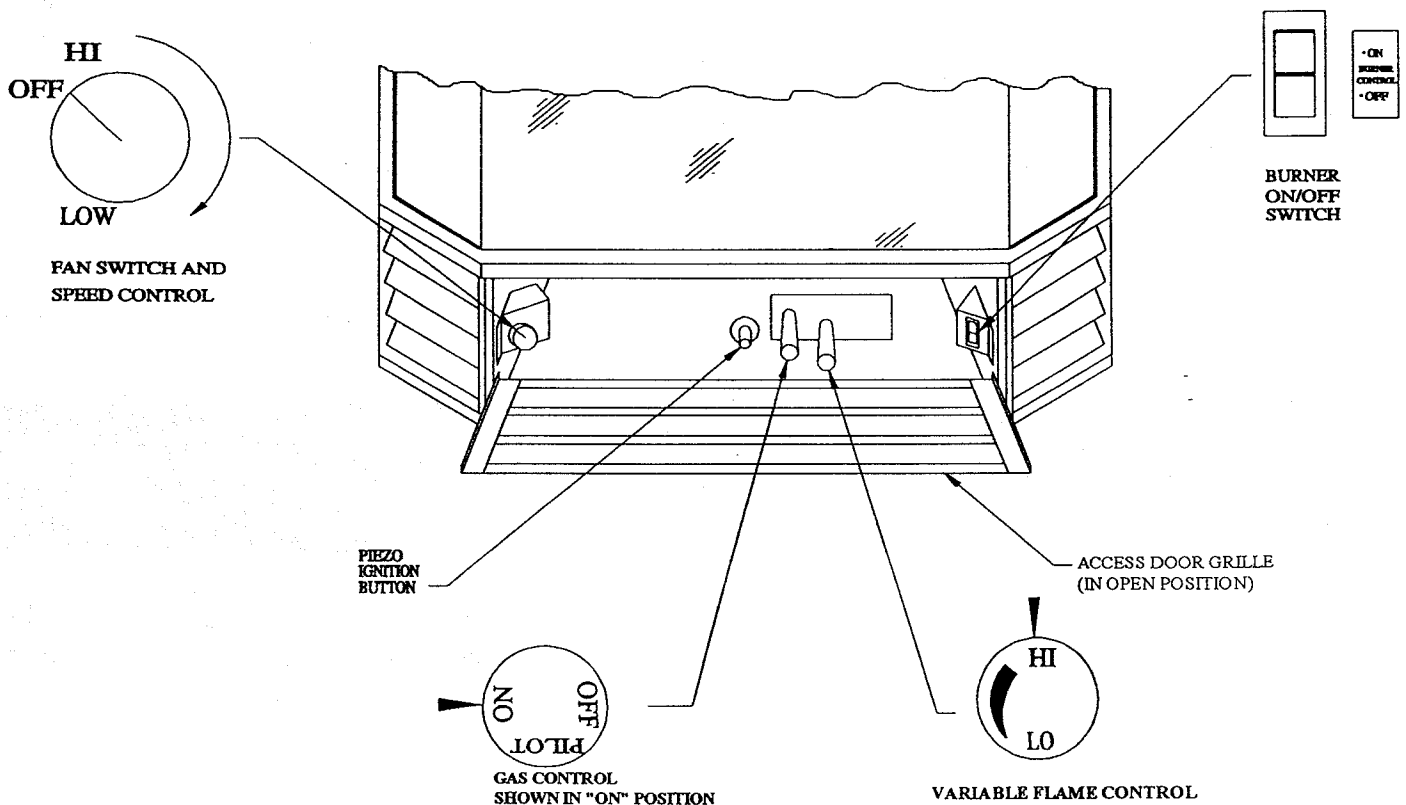

FIGURE 2

2.2 LIGHTING INSTRUCTIONS

FOR YOUR SAFETY, READ BEFORE LIGHTING

WARNING: If you do not follow these instructions exactly, a fire or explosion may result causing property damage, personal injury or loss of life.

- A. This appliance is provided with a standing pilot flame. When lighting the pilot, follow these instructions exactly:
- B. **BEFORE LIGHTING** smell all around the appliance area for gas. Be sure to smell next to the floor because some gas is heavier than air and will settle on the floor.

WHAT TO DO IF YOU SMELL GAS

- * Do not try to light any appliance.
 - * Do not touch any electrical switch: do not use any phone in your building.
 - * Immediately call your gas supplier from a neighbor's phone. Follow the gas suppliers instructions.
 - * If you cannot reach your gas supplier, call the fire department.
- C. Use only your hand to push in or turn the gas control knob. Never use tools. If the knob will not push in or turn by hand, do not try to force or repair it, call a qualified service technician. Forcing or attempted repair may result in a fire or explosion.
 - D. Do not use this appliance if any part has been under water. Immediately call a qualified service technician to inspect the appliance and to replace any part of the control system and any gas control which has been under water.

LIGHTING PROCEDURE

1. **"STOP!"** Read the safety information in the previous section.
2. Set the thermostat to the lowest setting.
3. Turn off all electrical power to the appliance.
4. Open the access door grille, hinged to open downward, by pulling the top grille bar toward you.
5. Push in the gas control knob slightly and turn clockwise → to the "OFF" position as shown in Figure 3.

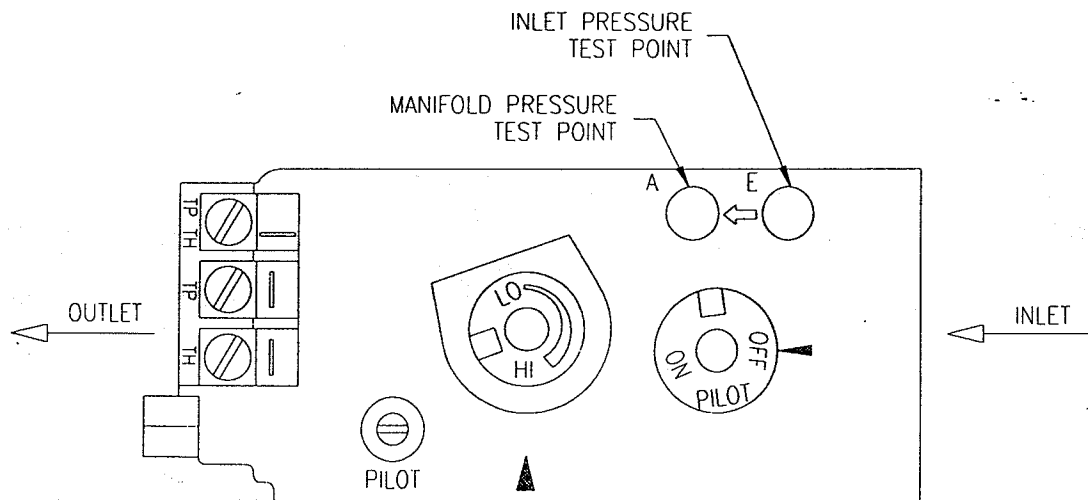

Figure 3

6. Wait a minimum of five minutes to clear out any residual gas. If you then smell gas, **STOP!** Follow "B" in the Lighting Instruction section described on the previous page. If you don't smell gas, go to the next step.
7. Press in the valve knob and turn counterclockwise ← to the "PILOT" position.
8. Push in the control knob all the way and hold it in. Immediately push the piezo ignition button (the red button to the left) repeatedly so that it clicks; continue until the pilot ignites. Maintain pressure on the control knob for about one minute after ignition. Then release the control knob; if the pilot flame goes out repeat step 8; if the pilot flame remains on then turn the valve knob counterclockwise ← to the "ON" position.
9. If the pilot lights, but will not stay on after several tries, turn the gas control knob to the "OFF" position and call your service technician or gas supplier. If the control knob does not pop out when released, **STOP** - shut off the gas supply to the control valve, and **IMMEDIATELY** call your service technician or gas supplier.
10. Turn the burner control to on.
11. Close the access door grille by lifting it and allow the springs to pull it closed.
12. If equipped with a wall switch, select the "ON" position. If equipped with a thermostat or auxiliary control, set it to the desired setting.

SHUTDOWN PROCEDURE

1. To turn off the main burner only, turn off the wall switch, thermostat, or On/Off switch located behind the access grille.
2. For complete shutdown of the appliance, depress the valve control knob and turn it clockwise → to the "OFF" position.

2.3 HEAT OUTPUT ADJUSTMENT

The valve supplied with the appliance has a HI/LO knob to control the heat output and flame height.

2.4 FAN OPERATION

The fan control knob is located behind the access door grille assembly and may be adjusted to the following settings:

OFF: Turn the control fully counterclockwise ← .

Variable Speed Setting:

Turn the control to the desired setting. When the knob is turned fully clockwise, → the fan will be on low speed.

2.5 REMOTE CONTROL OPERATION

An optional hand held remote control kit for turning the unit On and Off, is also available. Detailed instructions for the optional Remote Control are included with the kit.

3.0 INSTALLATION

3.1 INSTALLATION & SAFETY NOTES

Read all instructions before beginning and follow them carefully during installation to ensure maximum benefit and safety. Failure to follow these instructions will void your warranty and may present a fire hazard. See the Osburn warranty at the back of this manual for improper installation disclaimers. This fireplace and its components are certified and safe when installed in accordance with this manual.

WARNING: Do not connect 120 VAC to the gas control valve or its wiring, as this will damage the valve.

3.2 UNPACKING

The fireplace is shipped with the logs and coals in separate packages inside the firebox. The three grille assemblies are packaged separately. The top louvre assembly is in a box on top of the appliance. All other parts of the fireplace are in position.

Report to your dealer any parts that may have been damaged in shipment (**specifically check the glass condition**).

The best time to install the internally packaged parts is after installation and connection of the gas line. The door needs to be removed before installing the coals and logs.

1. Remove the louvre package from the top of the unit.
2. Release the top and bottom door latches.
3. Pull the door forward and remove it.
4. Handle the door very carefully and set it **in a safe place**, away from traffic areas.

NOTE: The One Piece Glass Is Very Fragile And Is Expensive To Replace.

5. Remove the packaging containing the logs and coals.

3.3 INSTALLATION

For satisfactory results it is necessary to plan certain aspects of the installation prior to the appliance's final positioning. These include the vent system, the gas piping, the wiring, hearth, mantels and facing.

NOTE: All Installations Require Venting.

3.3.1 Minimum Clearances To Combustible Construction

This top venting fireplace is suitable for installation in new construction and wood framed enclosures.

Minimum enclosures are as follows:

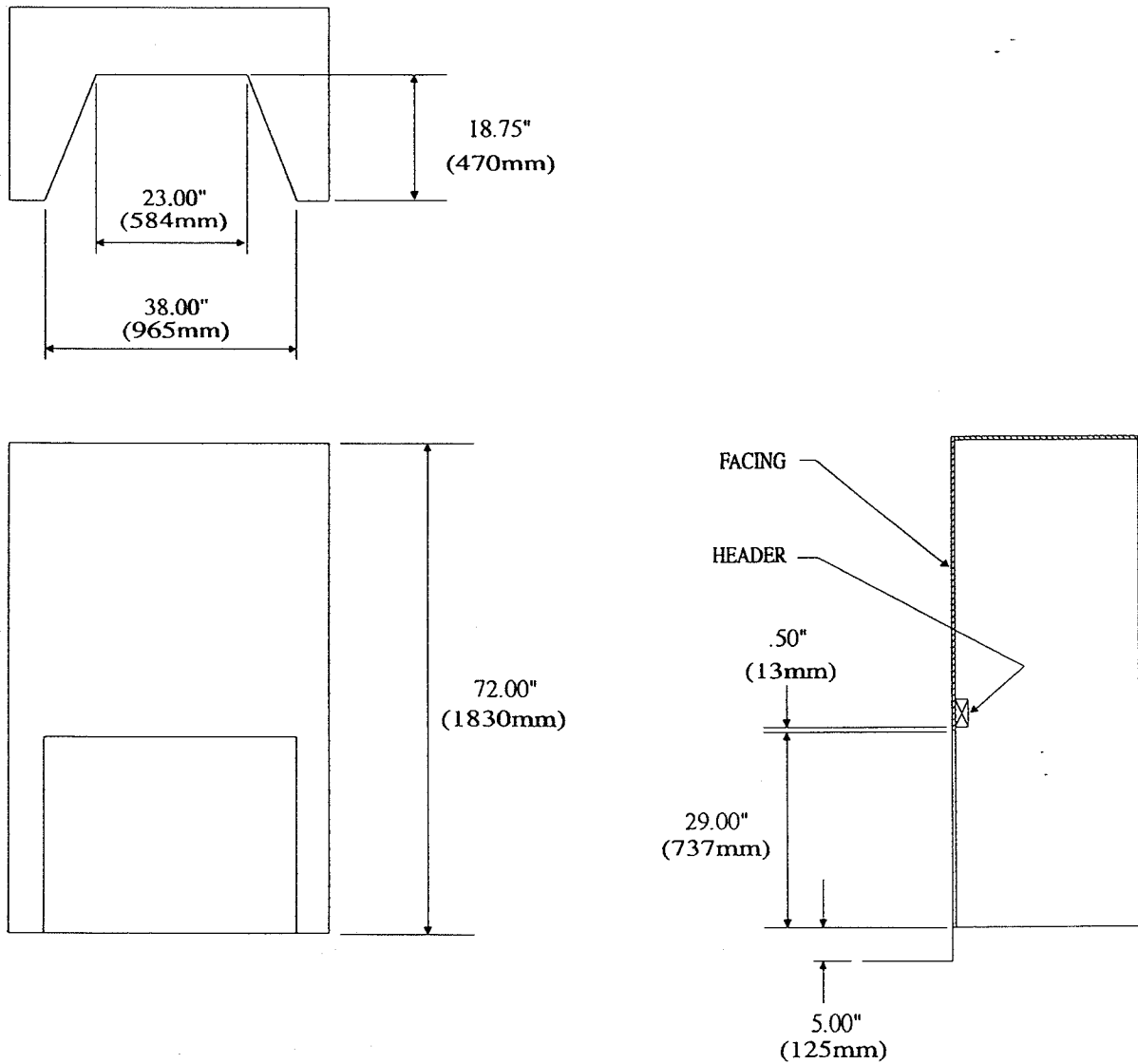

Figure 4

Minimum Fireplace Clearances To Combustibles

Floor	0"	(see hearth extension requirements in Flooring Options)
Facing	0"	
Sidewall	10"	(255mm) (measured from glass)
Ceiling	52"	(1320mm) (measured from top louvre)
Ceiling	72"	(1830mm) (overall height)
Mantle Post Width	43"	(1090mm) (between posts)
Top Standoffs	0"	(to 2" x 4" construction)
Vent	2"	(50mm)
Mantle	28"	(711mm) (measured from top louvre to 10" (255mm) mantle)
Mantle	18"	(457mm) (measured from top louvre to 7 1/4" (184mm) mantle)
Mantle	12"	(305mm) (measured from top louvre to 4" (102mm) mantle)

NOTE: No combustibles permitted above unit within the enclosure for a distance of 72" (1830mm) above the floor.

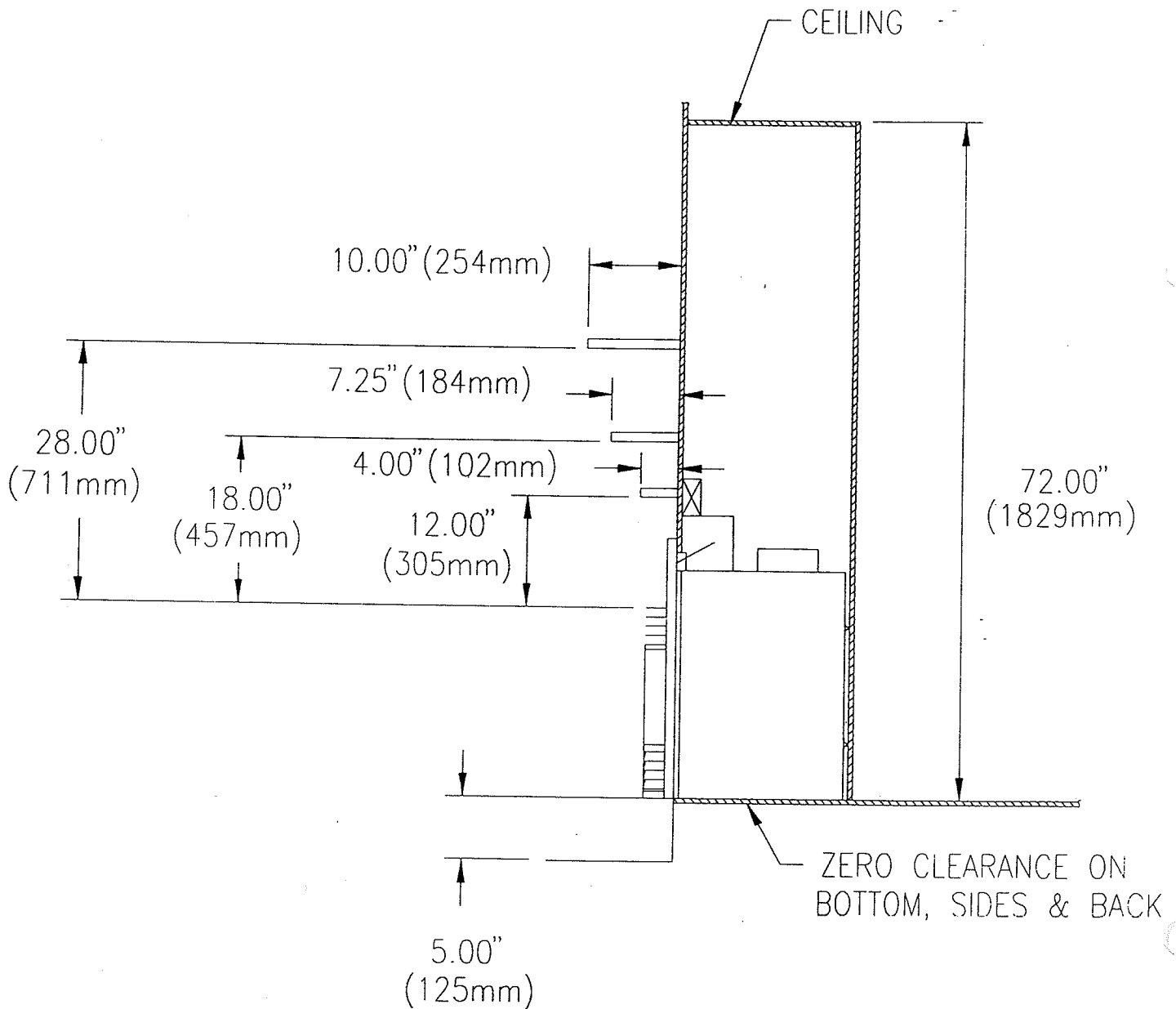

Figure 5

3.3.2 Installation Of Flooring & Framing

CAUTION: Due to high temperatures, the room heater should be located out of traffic and away from furniture and draperies. Provide a minimum 48" (1220mm) front clearance to the unit.

Flooring Options

Install either with a non-combustible hearth extension which projects 18" in front of the unit, or as shown below.

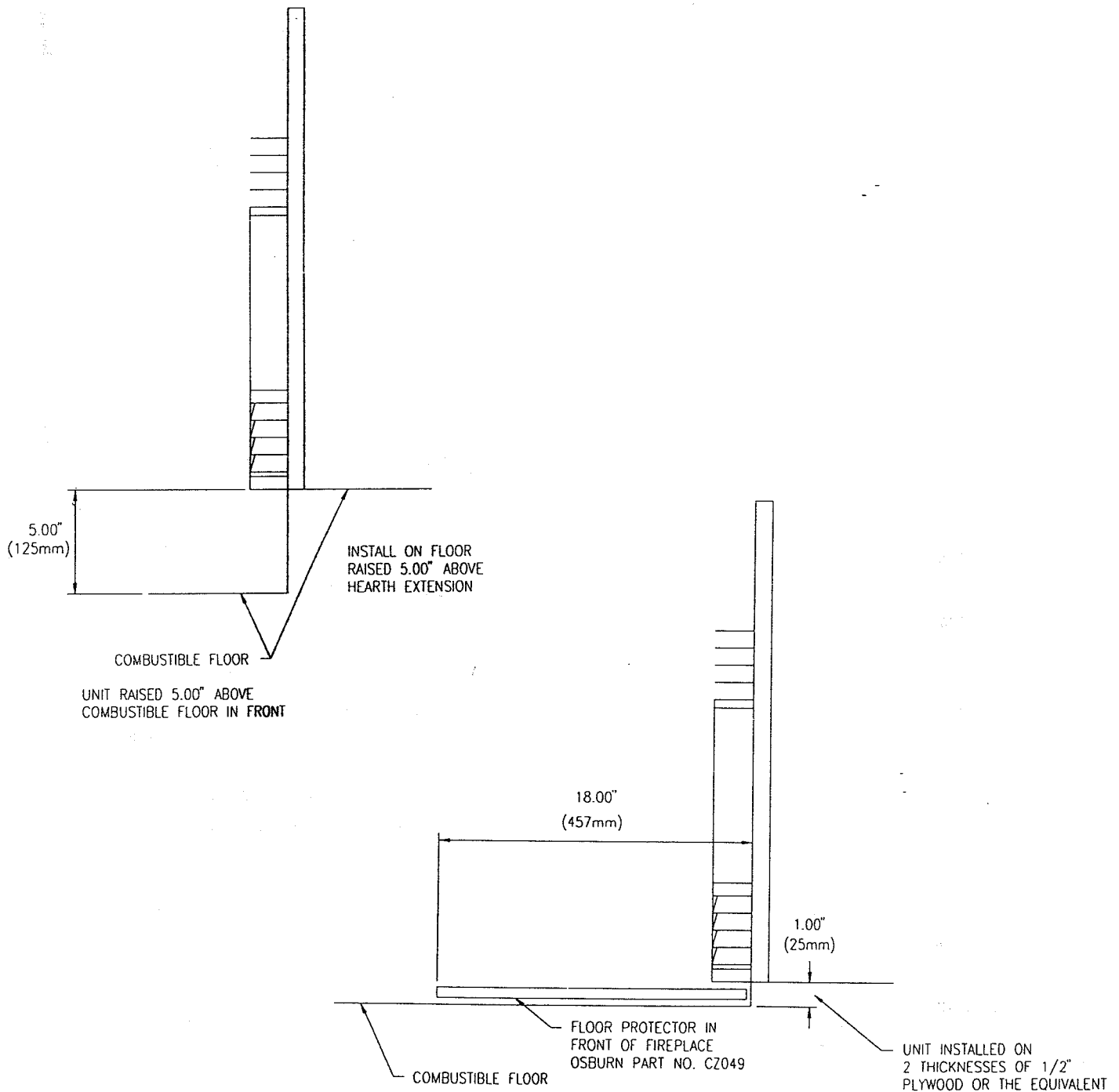

Figure 6

Framing

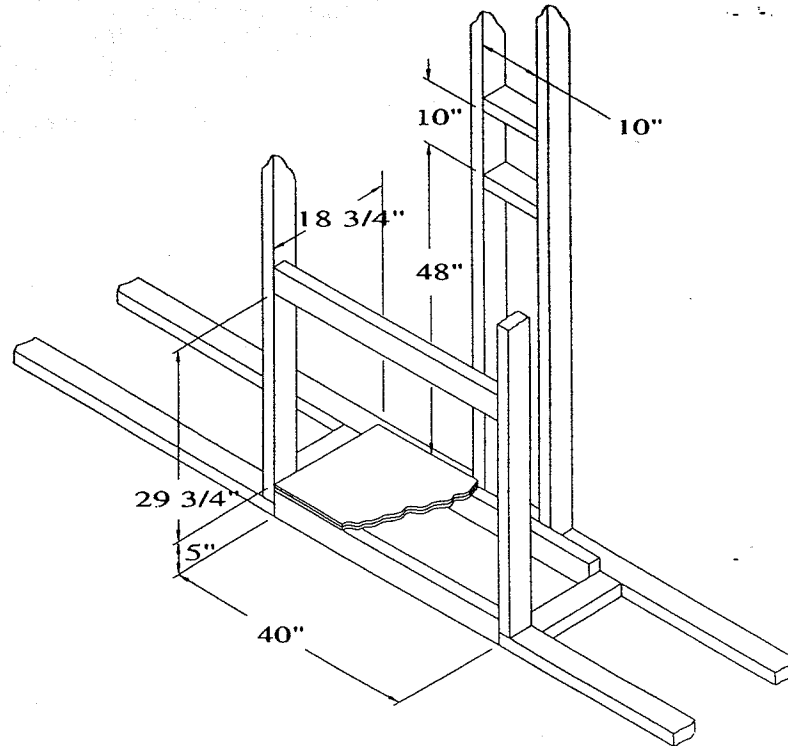

Figure 7

1. The drywall trim allows for 1/2" (13mm) of drywall or finish facing material. The fireplace may be installed directly on and/or against standard combustible building materials.
2. Frame-in the enclosure for the fireplace with standard framing material. The framed opening for the fireplace is 29.75" high x 40" wide x 18.75" deep as shown in Figure 7. An additional 1" (25mm) or 5" (125mm) in height is required depending on flooring options used. For the header, install a 2" x 4" on edge as shown.
3. For exterior walls, install vapor barrier and insulate the enclosure to the same degree as the rest of the house, or according to local installation codes. In colder climates, if the unit is to be installed against an exterior wall or chase, insulate the exterior walls according to local installation codes.
4. Extend the vent chase to a minimum ceiling height of 72" (1830mm) at the same width and depth mentioned above. Keep this area above the unit clear of combustible construction.
5. The basic vent kit consists of a 24" vertical length on the fireplace, followed by a 90° elbow and a 6", 9" or 12" horizontal length to suit wall thickness. Frame as shown. Allow 2" clearance to the vent. Refer to 3.3.3 for chimney vent installation.
6. Secure drywall trim to framing studs and header.

3.3.3 Chimney Vent Installation

Refer to manufacturers installation guide.

Typical chimney installation:

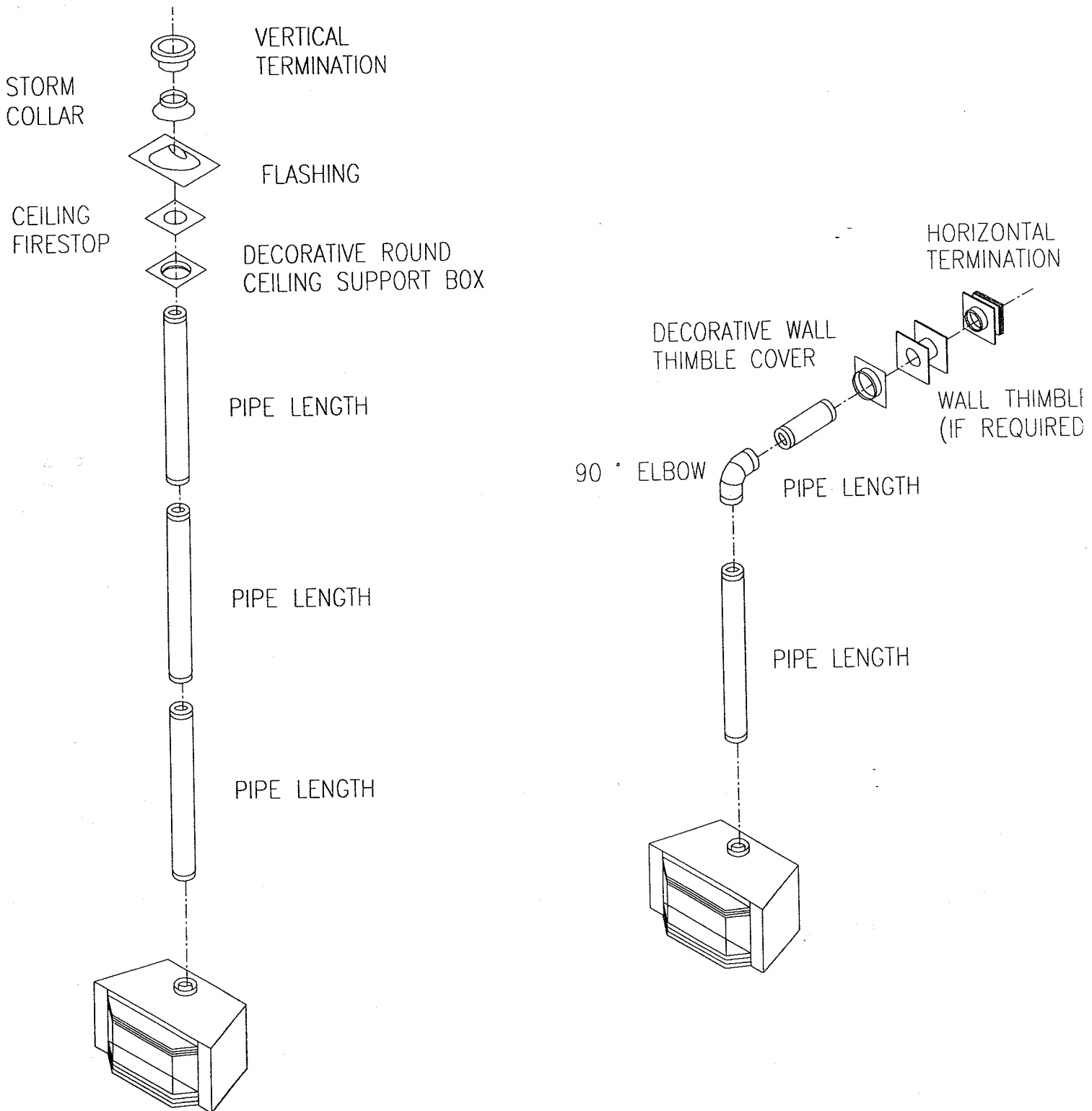

Figure 8

The fireplace must be connected only to Simpson Duravent model DV-GS vent. Install the chimney according to the manufacturer's instructions. Use a maximum of two 90° elbows or four 45° elbows. Slope horizontal pipe at least 1/4" (6mm) rise per foot of horizontal run. Allow 2" (50mm) clearance to the vent. A vinyl siding standoff must be used when terminating horizontal to vinyl siding. Refer to the graph for allowable vent configurations.

The minimum vent system for horizontal termination must consist of:

- 24" vertical length directly on top of fireplace
- 90° elbow
- 6", 9" or 12" length horizontally
- horizontal termination cap

Recommended lengths for a given wall thickness, and the unit installed flush to the back wall are:

Horizontal Length (inch)	Wall Thickness (inch)
6	4 to 6
9	7 to 9
12	10 to 12

The maximum horizontal vent system consists of:

- 4' vertical length directly on top of the fireplace
- 90° elbow
- 13' maximum horizontal lengths
- horizontal termination
- snorkel kits can be used if needed. (Part #981 - 36" or Part #982 - 14")

Do not exceed more than 13' of horizontal length of vent.

The maximum vertical system consists of:

- up to 30' of vertical lengths
- firestop
- flashing
- collar
- high wind cap 980 (use only the high wind cap)

Use a ceiling firestop when penetrating a ceiling. Use a round support box/wall thimble when penetrating an inside wall, or on an outside wall only when additional support or decorative trim is required. The round support box is not required on basic instructions.

NOTE: In Canada local codes may require the use of a wall thimble on horizontal termination. Use part #942.

ALLOWABLE VENT INSTALLATIONS

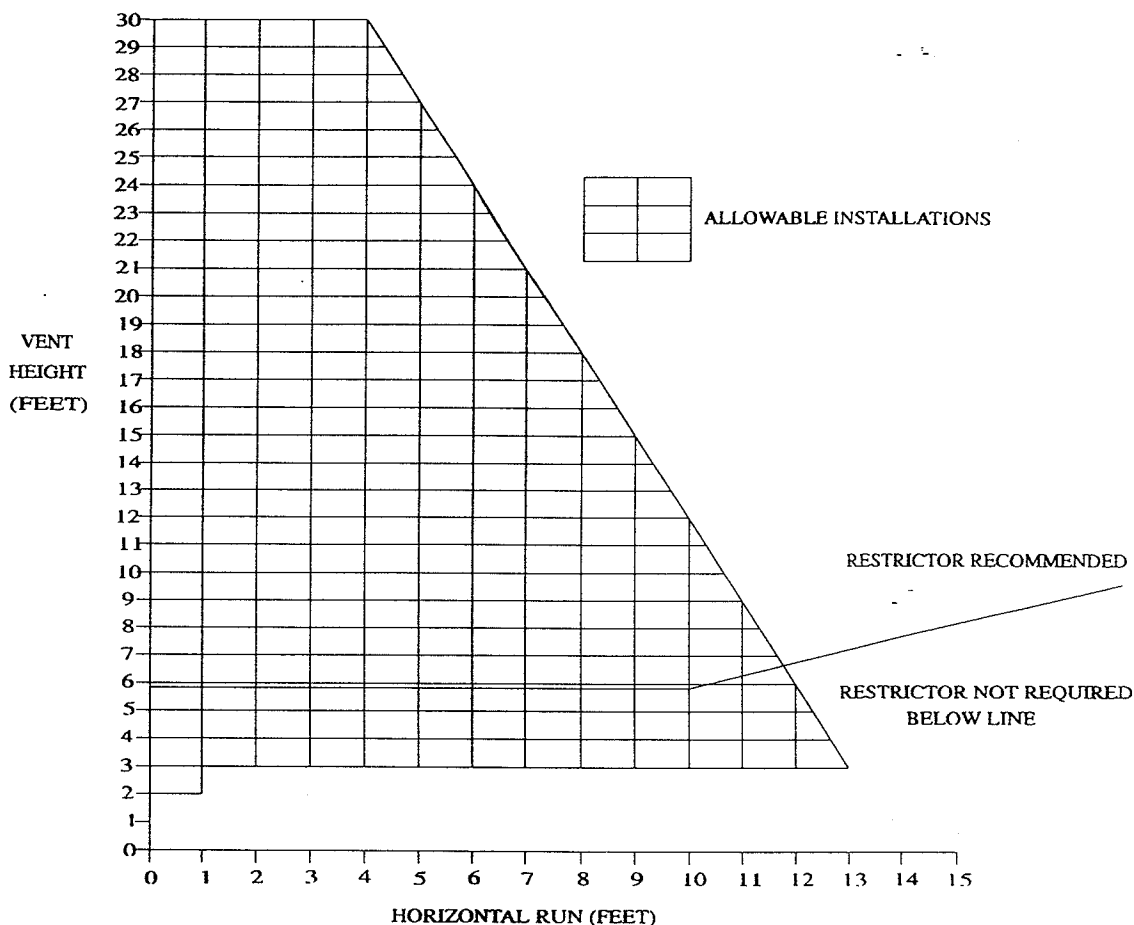

USE OF SEALANT

Sealant is recommended on vent systems of more than four joints. Elbows are considered to be the equivalent of two joints. On longer vent runs, especially vertical runs, sealant will ensure that the combustion air enters from outdoors, and not through the vent joints. Use Mil-Pac Black sealant (not silicone), available from local suppliers or Osburn dealers, on the inner pipe joint, applying the sealant around the outside of the male part of the vent. A bead of silicone should be used on the outside of the joint after assembly in order to seal the supply air.

RESTRICTOR INSTALLATION

Restrictors are recommended for all vertical vent systems, and for some horizontal systems which have excessive draft. Restrictors compensate for high draft, restore the visual flame height, and limit excessive cooling resulting from too much secondary air. Restrictors are supplied by Osburn with the vent cap, they are also available separately by using the following part numbers:

Vertical Cap Restrictor	CZ054
Horizontal Cap Restrictor	CZ055

Install the restrictor using the instructions supplied with the part.

Refer to the allowable vent configuration graph for systems where a restrictor is recommended. Vent systems above the line will have better visual flame height when a restrictor is used.

VENT TERMINAL LOCATIONS

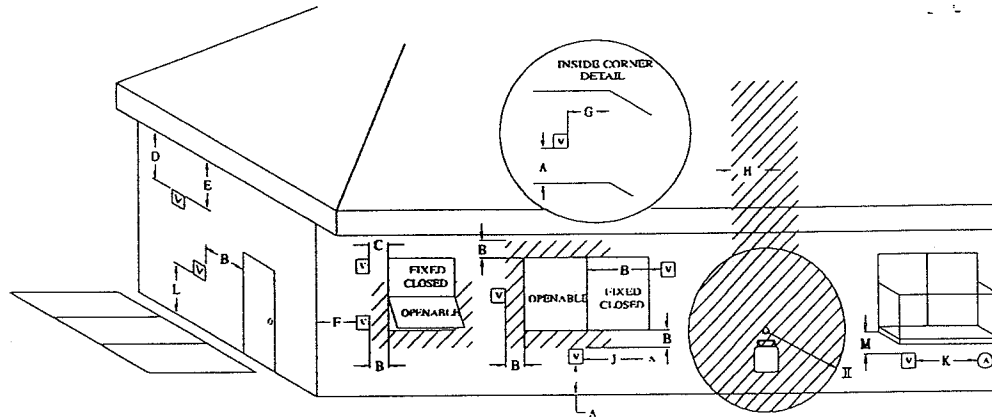
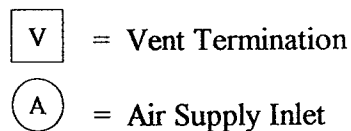

Figure 9



- A = clearances above grade, veranda, porch, deck, or balcony [* 12" (30cm) minimum]
 - B = clearance to window or door that may be opened [* 12" (30cm) minimum]
 - C = clearance to permanently closed window [minimum 12" (30cm) recommended to prevent condensation on window]
 - D = vertical clearance to ventilated soffit located above the terminal within a horizontal distance of 2' (60cm) from the center-line of the terminal [36" (cm) minimum]
 - E = clearance to un-ventilated soffit [36" (cm) minimum]
 - F = clearance to outside corner = 36"
 - G = clearance to inside corner = 36"
 - H = * not to be installed above a meter/regulator assembly within 3' (90cm) horizontally from the center-line of the regulator
 - I = clearance to service regulator vent outlet [* 6' (1.8 m) minimum]
 - J = clearance to non-mechanical air supply inlet to building or the combustion air inlet to any other appliance [* 12" (30cm) minimum]
 - K = clearance to a mechanical air supply inlet [* 6' (1.8m) minimum]
 - L = † clearance above paved side-walk or a paved driveway located on public property [* 7' (2.1m) minimum]
 - M = clearance under veranda, porch, deck, or balcony [* 12" (30cm) minimum ‡]
- † a vent shall not terminate directly above a side-walk or paved driveway which is located between two single family dwellings and serves both dwellings*
- ‡ only permitted if veranda, porch, deck, or balcony is fully open on a minimum of 2 sides beneath the floor*
- * as specified in CGA B149 Installation Code (1991) **NOTE:** local codes or regulations may require different clearances
- * follow ANSI Z223.1 for U.S.A.

3.3.4 Gas Line Installation

- Install supply line using any piping approved for your installation meeting CAN/CGA 6.10, AGA 3, ANSI Z21.24 or Z21.45. A qualified gas fitter should install the gas line in accordance with all local building codes. If codes permit, coiled copper tubing may be used for gas supply.
- A plugged tapping is provided on the gas control for a test gauge connection to measure the manifold pressure, as well as a connection for inlet pressure measurement.
- This appliance must be isolated from the gas supply piping system by closing its individual manual shut off valve during any pressure testing of the gas supply piping system at test pressures equal to or less than 1/2 psig (3.45 kPa).
- The appliance and its individual shut off valve must be disconnected from the gas supply piping system during any pressure testing of the system at test pressures in excess of 1/2 psig (3.45 kPa).
- Install the gas line as follows:
 1. The gas line on the right side of the fireplace is shown in figure 10. An AGA & CGA approved shutoff valve can be installed to the flexline if so desired.
 2. Purge the gas line of air.
 3. Test the gas line for leaks using an electronic gas leak detector or soapy solution.

WARNING: Do not use an open flame to test for gas leaks.

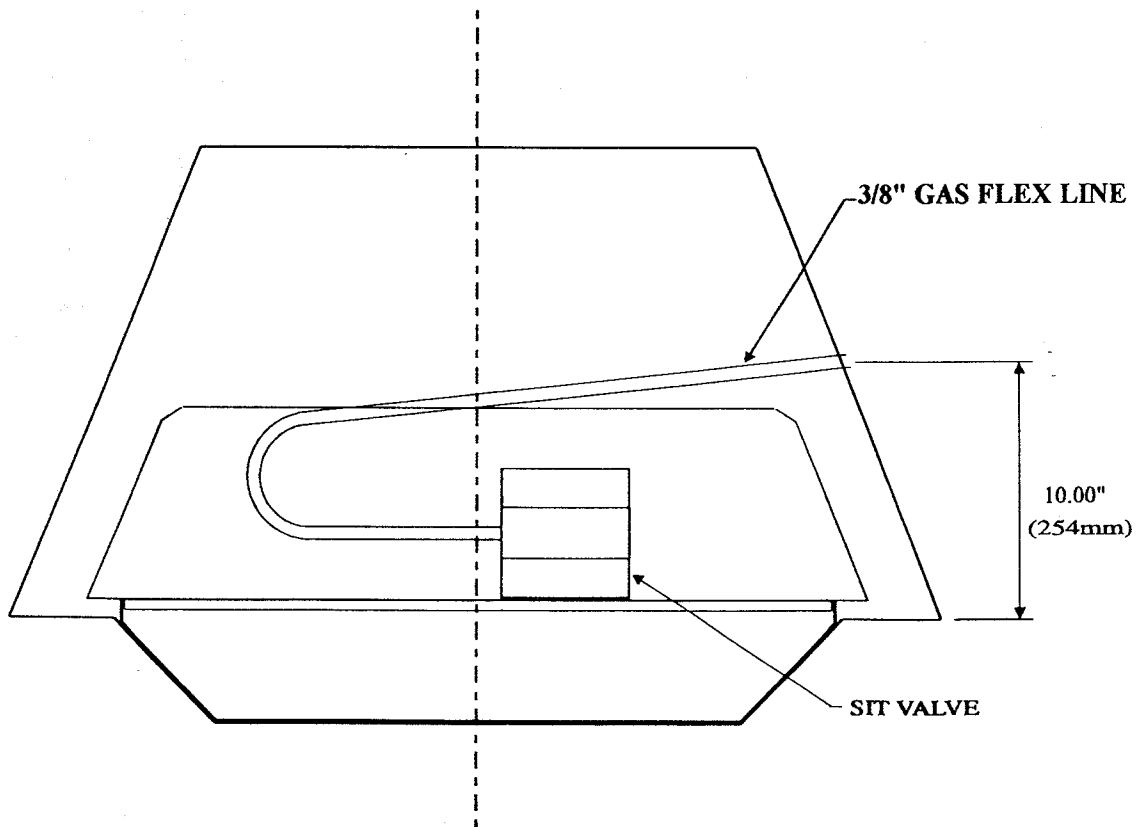

Figure 10

3.3.5 Thermostat, Wall Switch, Or Remote Control Installation

For your convenience, the fireplace can be operated by a thermostat, a wall switch or a remote control. Millivolt thermostats and remote control kits are available from any authorized Osburn dealer.

NOTE: The thermostat or wall switch **MUST** be rated for millivolt use. Minimize splicing in all millivolt wiring & solder all unavoidable splices.

1. Mount the thermostat or wall switch in the desired location and run "*two conductor thermostat wire*" to the heater's lower right hand corner, close to the gas supply line. Purchase "*two conductor thermostat wire*," which is not provided, at any local supplier. The gauge of thermostat wire will determine the maximum wire length and distance at which to locate the thermostat or wall switch. See Table 2 below and the information packaged with thermostat. Be aware that as the length of wire increases, the probability of adequate operating voltage decreases.

TABLE 2 THERMOSTAT WIRE INFORMATION

AWG	WIRE SIZE		MAX. WIRE LENGTH	
	mm	ft.	m	
22	0.6	10	3.1	
20	0.8	25	7.6	
18	1.0	40	12.2	
16	1.3	64	19.5	
14	1.6	100	30.5	

2. While the fireplace is being installed and the gas line is connected, solder a female spade connector to each wire and connect them to the male connectors provided on the rear of the burner switch.
3. Check tests can be performed on the valve by using the trouble shooting guide.

To install remote control, please read instructions included with kit.

3.3.6 Wiring Connections

Burner Switch

1. If employing additional switches, connect the wiring for the thermostat or the wall switch as noted in #2 of section 3.3.5.

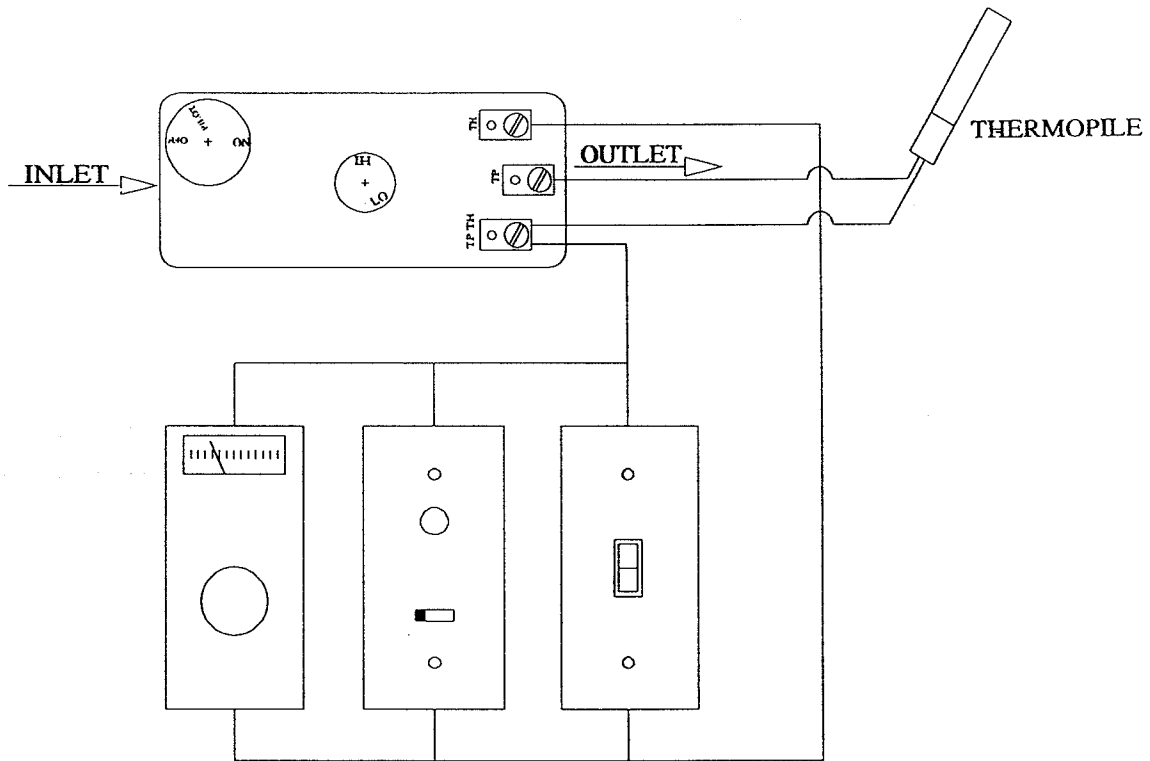

Figure 11

Fan Wiring

Run electrical power to the left side of the appliance, and secure it with a strain relief to the hole provided. Fan wiring is accessible both from the side and through the left grille opening at the front of the appliance.

3.3.7 Fireplace Faceplate Installation

See instructions included with faceplate.

3.3.8 Firebox Component Installation

Installing Logs

Proper log placement is very important. The logs are designed to be installed in only one position so that flames do not impinge on them.

1. Place the front and rear lower logs as shown in Figure 12 below:
 - * Position the front log against the stop on the right
 - * Position the rear log against the stop on the left.

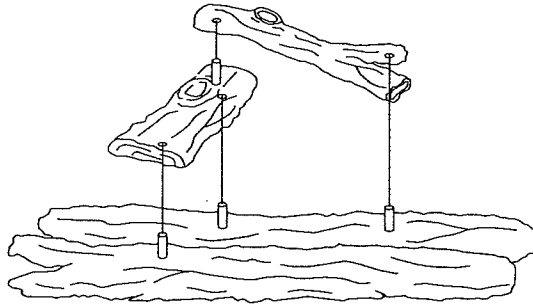

Figure 12

2. Place the upper left log on top of the two lower logs ensuring that the split log knot is to the rear of the firebox and the pins fit into the recesses in the upper logs as shown above. Push the log towards the back of the appliance.

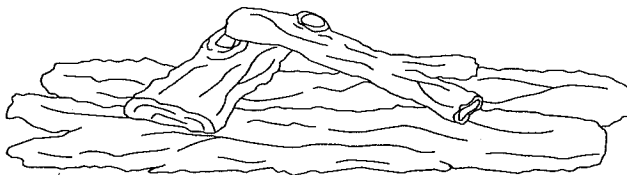

Figure 13

3. Place the upper right log on top of the other logs.
4. Verify that the placement of the factory installed brick panels is as follows:
 - * The brick panels should be up against the firebox sides and as far to the rear of the firebox as possible.

Installing Coals

The coals should be placed along the coal tray on top of the burner, located in front of and below the front log, as shown in Figure 14 below. The coals extend around the log ends as shown.

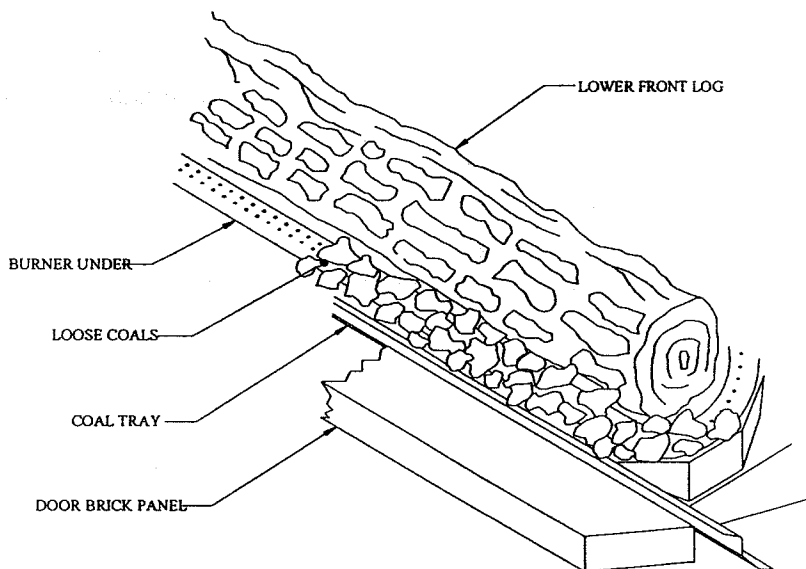

Figure 14

Installing The Door And Louvre Assembly

1. Install the door by holding it in position while securing the 4 draw latches around the door.
2. Install the top louvre assembly above the door as shown.

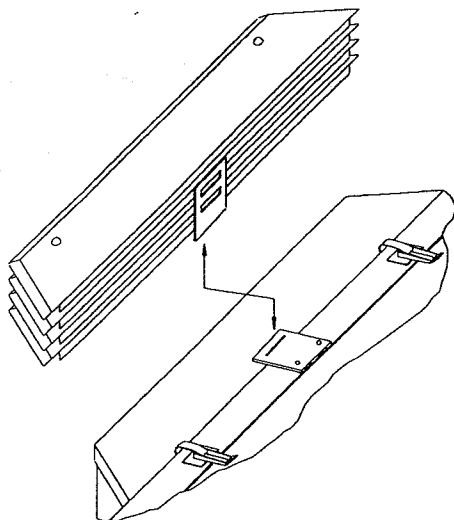

Figure 15

Installing Grille Assemblies

Handle the grilles with care as they may scratch easily. Follow the instructions included with the grille packaging.

3.3.9 Initial Firing

When lit for the first few times, the appliance may emit an odor resulting from evaporation of paint and lubricants used in the manufacturing process. Open a door or window for ventilation. Anyone with a respiratory condition may need to leave the room during the initial firings.

Occasionally, after a cold start, vapor may condense and fog the glass, and the flames may be partially blue. After a few minutes the moisture will disappear and after several more minutes the flames should become yellow.

3.3.9.1 Manifold Pressure Regulator Adjustment

The manifold pressure regulator controls gas input and flame height, and is preadjusted at the factory. No further adjustment is required. Manifold pressure can be verified only

3.3.9.2 Pilot Flame Adjustment

For proper operation, the pilot and main burner flames must be steady and not lifting off or floating. The top $3/8"$ - $1/2"$ (10-13mm) of the thermopile should be engulfed by the pilot flame. The pilot flame adjustment should be performed by a qualified service person only. To adjust the pilot flame, turn the pilot adjustment screw counterclockwise ← to increase, and clockwise → to decrease the flame. Ensure that the pilot flame completely engulfs the thermopile, as shown in Figure 16.

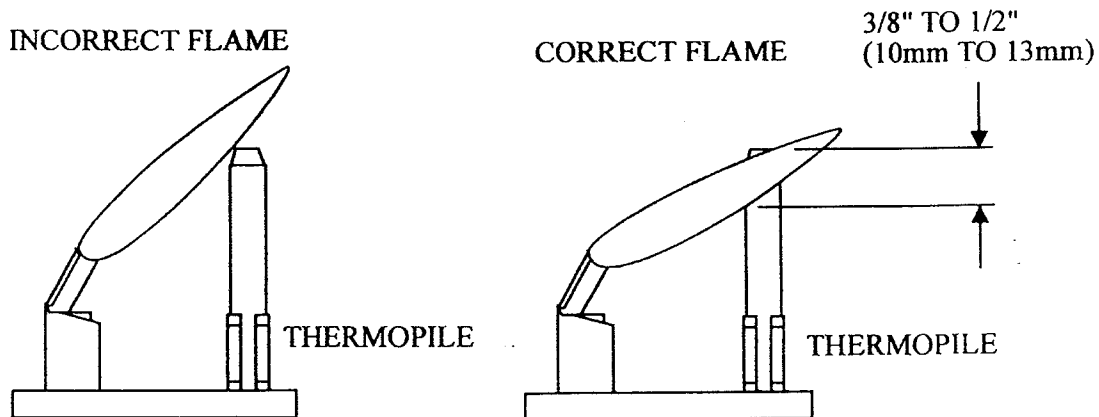

Figure 16

3.3.9.3 Altitude Adjustment

All valves have been preset and certified for installation at elevations from 0 - 4500 feet (1-1370m) above sea level.

When installing this fireplace at higher elevations, it is necessary to decrease the input rating, by changing the existing burner orifice to a smaller size. Input should be reduced 4% for each additional 1000 feet above sea level.

Use Tables 4A & 4B or check with the local gas authorities for proper orifice size identification. For the USA, derate the heater from sea level according to the gas installation code.

TABLE 4A ALTITUDE ADJUSTMENT BY CHANGING ORIFICE (NATURAL GAS ONLY)

ALTITUDE up to (ft)	REDUCTION (%)	ORIFICE SIZE	TARGET INPUT	MANIFOLD PRESSURE (in. wc)
4500	-	31	40,000	3.5
5500	4	32	38,400	
6500	8	33	36,800	
7500	12	34	35,200	
8500	16	35	33,600	
9500	20	35	32,000	
10500	24	36	30,400	
11500	28	37	28,800	

TABLE 4B ALTITUDE ADJUSTMENT BY CHANGING ORIFICE (PROPANE/LP GAS ONLY)

ALTITUDE up to (ft)	REDUCTION (%)	ORIFICE SIZE	TARGET INPUT	MANIFOLD PRESSURE (in. wc)
4500	-	47	40,000	10.5
5500	4	48	38,400	
6500	8	48	36,800	
7500	12	49	35,200	
8500	16	49	33,600	
9500	20	50	32,000	
10500	24	50	30,400	
11500	28	50	28,800	

4.0 MAINTENANCE

4.1 MAINTENANCE SAFETY

Turn off the gas to the main burner and allow the heater to cool for up to 30 minutes before servicing. Service and repair should be done by a qualified service person. The appliance should be inspected before use and at least annually by a professional service technician. More frequent cleaning may be required due to excessive lint from carpeting, bedding material, etc. It is important that the access door compartment, burner, and circulating air passage-ways be kept clean to provide for adequate combustion and ventilation air flow. Do not substitute materials or use components other than factory supplied.

4.2 RECOMMENDED SERVICE

1. Examine the venting system periodically.
2. Visually check the burner and pilot flame periodically. Visually check height and color of flame.
3. Clean the glass as needed. See section 4.3 for instructions on glass cleaning.
4. Have the appliance inspected annually by a professional service technician.
5. Clean the appliance periodically.

4.3 GLASS CLEANING

The inside of the glass may require periodic cleaning to remove deposits left from impurities in the gas and combustion air. For best results, use a ceramic glass cleaner or polish. A suitable cleaner is available from your dealer. Do not clean while hot. Do not use abrasive cleaners.

4.4 CLEANING OF GOLD PLATED SURFACES

Take special care and **DO NOT** use chemical or abrasive cleaners. Wipe only with a soft damp cotton cloth to maintain original brilliance. **CAUTION:** Vigorous wiping may damage the gold finish.

4.5 BURNER & PILOT CLEANING

Periodic cleaning is necessary for proper operation.

1. Refer to section 4.7, remove the burner and check to make sure that the burner orifice is clean.
2. Visually inspect the pilot. Brush or blow away any dust, lint or foreign debris. If the pilot orifice is plugged, disassembly may be required to remove any foreign material from the orifice or tubing. When the appliance is back in service, check the burner flame pattern with the Pilot Flame Figures in section 3.3.9.2. For relighting, refer to the lighting instructions in section 2.2.

4.6 FAN REPLACEMENT & ELECTRICAL SCHEMATIC

Fan Service

1. Turn off all electrical power to the fireplace.
 2. Remove the top louver assembly and door (Figure 15).
 3. Remove the two fan bracket securing screws.
 4. Remove the electrical cover by loosening 2 screws behind the left grille.
 5. Remove the fan wire from the thermal switch.
 6. Disconnect the remaining fan wire.
 7. Remove the fan by sliding it forward and out.
-
5. Reassemble in reverse order.
 6. See Figure 17 for fan electrical schematic.

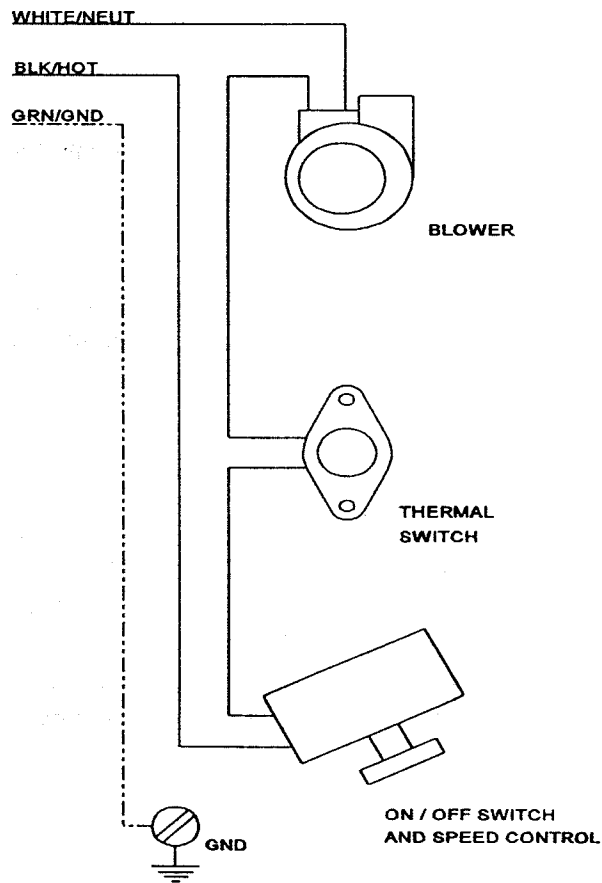

Figure 17

If necessary, the Fan Thermal Switch behind the left grille may be replaced as follows:

1. Ensure the fan switch is in the "OFF" position.
2. Remove the left grille assembly.
3. Remove the electrical cover by removing 2 screws.
4. Pull the fan thermal switch mount bracket out from the bottom.
5. Disconnect the two wires from the switch.
6. Remove the two screws securing the switch.
7. Reassemble in the reverse order.

4.7 FIREPLACE DISASSEMBLY & REASSEMBLY

The following procedure is to be performed by qualified service personnel ONLY.

Turn off the gas supply and allow the heater to cool before proceeding.

Refer to steps 1-3 of Unpacking section 3.2.

1. Remove the logs and coals.
2. Remove the burner tray assembly as a unit by lifting it up and out.
3. Remove the air dam at the bottom of the firebox by removing the 2 screws securing it. Note their positions.
4. Reassemble the components in reverse order.
 - One screw holding the pilot assembly to the pilot bracket.
 - Three screws holding the pilot cover plate to the firebox bottom.

Remove the valve as follows:

1. Follow steps 1 - 3 above.
2. Undo the gas flexline connection at the gas valve. These fittings are flared and do not require sealant.
3. Remove the screw securing the pilot assembly to the pilot bracket.
4. Remove the 3 screws securing the pilot cover plate and remove the plate.
5. Remove the nut securing the orifice to the firebox bottom.
6. Remove the 4 screws holding the valve bracket to the firebox bottom.
7. Remove the blue wires to the valve. Once the fasteners are removed, the valve/pilot assembly can be rotated out through the front of the appliance as a complete unit.

Brick Panels

Decorative brick panels which develop cracks are still serviceable and should not be moved out of position once fired, since strength deteriorates after firing.

5.0 TROUBLE SHOOTING

SYMPTOM	POSSIBLE CAUSE	CORRECTIVE ACTION	
I. Pilot will not light after repeated triggering of the red piezo ignition button	A. No spark at electrode (weak or no heat source for pilot ignition)		
	1. Improper ignition	1. Align the electrode with 1/8" gap to pilot hood	
	2. Poor connections at starter and ignition electrode	2. Reconnect if loose	
	3. Broken ceramic cover on ignition electrode	3. Replace pilot assembly	
	4. Defective piezo igniter	4. Replace piezo igniter	
	5. Poor grounding of piezo igniter	5. Tighten mounting nut and/or igniter screws	
	B. No gas or low gas pressure		
	1. Gas line shut off(s) may not be turned on	1. Turn on shut-off valves	
	2. No gas supply (LPG)	2. Check propane tank, you may be out of fuel	
	3. Air in gas lines	3. Purge gas lines	
	4. Gas lines may not be connected	4. Connect all gas lines	
	5. Low pressure may be caused by bent line	5. Check for a kinked line	
	6. Valve control knob not fully depressed in "PILOT" position	6. Fully depress control knob	
	II. Pilot will not stay lit after following the lighting instructions	Thermopile/valve	
		1. Weak or improperly located pilot flame	1. Adjust and clean pilot. The flame must impinge on or engulf the thermopile, as shown in Figure 16.
2. Defective thermopile		2. Replace thermopile.	
3. Overheated thermopile		3. Make sure no foreign objects are in the way.	
4. Thermopile not installed properly		4. Make sure all wire connections at the gas valve terminals are tight and the thermopile is fully inserted into the mounting bracket.	
5. Open wire connection in pilot circuit	5. Check wire continuity and connections in the pilot circuit.		

SYMPTOM

POSSIBLE CAUSE

CORRECTIVE ACTION

II Pilot will not stay lit after following the lighting instructions (continued)

6. Defective valve

6. Connect the millivolt meter probes to the thermopile terminals on the gas valve. Turn the valve to the "PILOT" position, depress and light. If the meter reading is greater than 250 millivolts after 30 seconds, the thermopile is good. If the pilot does not stay lit, the valve is defective. Check section "B" below, before replacing valve.

B. Defective safety Circuit

1. Improperly wired

1. Rewire correctly.

2. Loose or defective connections

2. Check continuity, tighten wiring or connections and repair.

3. Defective electromagnet power unit (EPU)

3. Check and replace if required.

A. Valve/Switches

1. Valve control off

1. Turn to "ON" position.

2. Blockage at the burner (line, orifice, or ports)

2. Check and clean.

3. Defective wall switch or thermostat

3. Conduct a continuity test or jumper wire test and replace if defective.

4. Defective wiring or connections

4. Conduct a test with a jumper wire and repair as required.

5. Excessive length of thermostat wire from valve to wall switch or thermostat

5. Reduce wire length to less than 100 feet, or increase wire size.

6. Wall switch or thermostat incorrectly wired

6. Wire correctly.

7. Defective remote control

7. Check batteries and replace if required

8. Mismatched remote control frequencies

8. Match frequencies

A. Valve/Switches (continued)

9. Defective valve

9. Turn valve and "ON/OFF" switch to the "ON" position. Check with millivolt meter at terminals TP-TH. Millivolt meter should read greater than 100 millivolts, if the reading is OK and the burner does not come on, replace the gas valve.

10. Thermopile may not be generating sufficient voltage 325 mV Robertshaw/Honeywell

10. Recheck using the millivolt meter. The pilot flame may not be high enough for the flame to properly engulf the thermopile. If so, adjust and reset. If voltage is still insufficient, replace thermopile.

III Main burner will not light

SYMPTOM	POSSIBLE CAUSE	CORRECTIVE ACTION
III. Main burner will not light (continued)	11. Wall switch, thermostat, remote control, or wires are defective.	11. Follow previous corrective action, check switch and wiring. Replace where defective.
IV. Soot deposits on glass	1. Flame impingement on logs 2. Improper venturi setting 3. Foreign material impeding burner 4. Air inlet blocked or restricted 5. Vent system is restricted or inadequate	1. Adjust the log set to avoid direct flame impingement. Follow log placement instructions. 2. Ensure the air shutter is properly set to NG = .42" and LP = .27". 3. Ensure that no foreign material blocks burner flame ports. 4. Clean air inlets. 5. Correct flue as required.
V. Flame burns blue and lifts off burner	1. Insufficient combustion air being supplied 2. Manifold pressure set too high 3. Vent system restricted	1. Ensure that no foreign material blocks air inlets and that the burner shutter is correctly adjusted. Ensure the vent is adequate. 2. Check manifold pressure. 3. Check vent system
VI. Frequent pilot outage problem	See V	
VII. Flames impinge on firebox top	1. Vent system is restricted or inadequate 2. Manifold pressure too high	1. Correct flue as required. 2. Check manifold pressure as required.

6.0 REPLACEMENT PARTS

When requesting service or replacement parts for your fireplace, please provide model number and serial number. All parts listed below may be ordered from an authorized dealer.

BUILT-IN DIRECT VENT GAS FIREPLACE REPLACEMENT PARTS LIST

PART NO.	DESCRIPTION
CZ034	VALVE ASSEMBLY, NATURAL GAS
CZ045	VALVE ASSEMBLY, PROPANE
HG25	THERMOPILE
HG37	THERMOCOUPLE
HG35	PILOT ASSEMBLY, NATURAL GAS (INCL. IGNITER)
HG36	PILOT ASSEMBLY, PROPANE (INCL. IGNITER)
CZ0080	PILOT GAS LINE
HG04	IGNITER, PIEZO
HG38	CABLE, IGNITER
HG40	FLEX GAS LINE (INCL. FITTINGS)
HG43	EXTENSION KNOB, ON/OFF
HG44	EXTENSION KNOB, HIGH/LOW
HG51	PILOT ORIFICE, PROPANE
HG52	PILOT ORIFICE, NATURAL GAS
CZ0118	GASKET, GLASS (TADPOLE)
CZ0127	GASKET, DOOR
HE23	SWITCH, BURNER ON/OFF
CZ030	WIRE, ON/OFF (2 PER UNIT)
HE30	FAN THERMAL SWITCH
CZ005	SPEED CONTROL, FAN, 110v
CZ007	BLOWER ASSEMBLY (COMPLETE), 110v
HM13	GLASS, DOOR
CZ041	DOOR ASSEMBLY (COMPLETE)
HM22	GRILLE SPRING (2 PER UNIT)
CZ050	BRICK PANEL SET
CZ0024	BRICK PANEL, DOOR
CZ0035	BRICK PANEL, LEFT HAND REAR
CZ0116	BRICK PANEL, RIGHT HAND REAR
CZ0055	BRICK PANEL, LEFT HAND
CZ0056	BRICK PANEL, RIGHT HAND
CZ036	LOG SET
CZ0050	FRONT LOG
CZ0051	REAR LOG
CZ0053	TOP RIGHT LOG
CZ0054	TOP LEFT LOG

**BUILT-IN DIRECT VENT GAS FIREPLACE
REPLACEMENT PARTS LIST**

PART NO.	DESCRIPTION
CZ037 CZ0097 CZ0083 CZ0096 CZ035 CZ046	COALS BURNER ORIFICE JAM NUT BURNER ORIFICE, PROPANE BURNER ORIFICE, NATURAL GAS BURNER ASSEMBLY, NATURAL GAS (INCL. TRAY) BURNER ASSEMBLY, PROPANE (INCL. TRAY)
CZ043 BN0014 CZ0017 CZ0012 CZ0089 CZ0088 BC055 BC056 BC057 BC058 BC059 BC060 BC061 BC062 BC063 BC064	LOUVRE ASSEMBLY SCREW, LOUVRE (GOLD) SPACER, LOUVRE LOUVRE SUPPORT PEG TOP LOUVRE (GOLD) LOUVRE (BLACK) CENTER GRILLE (MET. BLACK) SIDE GRILLE (MET. BLACK) CENTER GRILLE (EBONY) SIDE GRILLE (EBONY) CENTER GRILLE (GREEN) SIDE GRILLE (GREEN) CENTER GRILLE (IVORY) SIDE GRILLE (IVORY) CENTER GRILLE (GOLD PLATED) SIDE GRILLE (GOLD PLATED)
CZ051 CZ053 HF71 HF72 HM75	UPPER DOOR TRIM LOWER DOOR TRIM UPPER DOOR TRIM SCREW (2 PER UNIT) UPPER DOOR TRIM NUT (2 PER UNIT) LOWER DOOR TRIM MAGNET (2 PER UNIT)

8.0 LABEL INFORMATION

FOR YOUR SAFETY READ BEFORE LIGHTING

WARNING: If you do not follow these instructions exactly, a fire or explosion may result causing property damage, personal injury or loss of life.

A This appliance has a starter pilot which must be lighted by the piezo starter. When lighting the pilot, follow these instructions exactly.

B BEFORE LIGHTING smell all around the appliance area for gas. Be sure to smell next to the floor because some gas is heavier than air and will settle on the floor.

WHAT TO DO IF YOU SMELL GAS

- Do not try to light any appliance.
- Do not touch any electric switch, do not use any phone in your building.

- Immediately call your gas supplier from a neighbour's phone. Follow the gas supplier's instructions.
- If you cannot reach your gas supplier, call the fire department.

C. Use only your hand to push in or turn the gas control knob. Never use tools. If the knob will not push in or turn by hand, don't try to repair it, call a qualified service technician. Force or attempted repair may result in a fire or explosion.

D. Do not use this appliance if any part has been under water. Immediately call a qualified service technician to inspect the appliance and to replace any part of the control system and any gas control which has been under water.

LIGHTING INSTRUCTIONS

1. STOP! Read the safety information above on this label. Set the thermostat to lowest setting.
2. Turn off all electric power to the appliance.
3. Open the control access grill.
4. Push in gas control knob slightly and turn clockwise to "OFF".

NOTE: Knob cannot be turned from "PILOT" to "OFF" unless knob is pushed in slightly. Do not force. Wait five (5) minutes to clear out any gas. If you then smell gas, STOP! Follow "B" in the safety information above on this label. If you don't smell gas, go to next step.

5. Turn knob on gas control counterclockwise to "PILOT".
6. Push in the control knob all the way and hold in. Immediately push the piezo ignition button (the red button on the left side) repeatedly until the pilot ignites.

7. Continue to hold the control knob in for about 1 minute after the pilot is lit. Release knob and it will pop back up. Pilot should remain lit. If it goes out repeat steps 1-8.
8. Turn gas control knob counterclockwise to "ON".
9. Close the control access grill.
10. Turn on all electric power to the appliance.
11. Set thermostat to desired setting.

- If knob does not pop up when released, stop and immediately call your service technician or gas supplier.
- If the pilot will not stay lit after several tries, turn the gas control knob to "OFF" and call your service technician or gas supplier.

HL 12/BV-002A

HL05 BV-000

CAUTION: HOT WHILE IN OPERATION. DO NOT TOUCH. KEEP CHILDREN, CLOTHING AND FURNITURE AWAY.

ATTENTION: CHAUD PENDANT LE FONCTIONNEMENT, NE TOUCHEZ PAS. TENIR ÉLOIGNÉS LES ENFANTS, LE VÊTEMENTS ET LES MEUBLES.

TO TURN OFF GAS TO APPLIANCE

1. Set the thermostat to lowest setting.
2. Turn off all electric power to the appliance if service is to be performed.
3. Open the control access grill.
4. Push in gas control knob slightly and turn clockwise to "OFF". Do not force.
5. Close the control access grill.

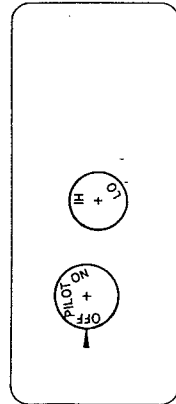

INSTRUCTIONS D'ALLUMAGE ET DE RALLUMAGE

1. Appuyer légèrement sur le bouton de contrôle du gaz, le tourner jusqu'à la position "OFF" (Arrêt) et attendre 5 minutes.
2. Appuyer légèrement sur le bouton et le tourner jusqu'à la position "PILOT" (Veilleuse).
3. Appuyer à fond sur le bouton et appuyer sur l'allumeur piézoélectrique rouge pour allumer la veilleuse. continuer d'appuyer sur le bouton pendant une minute ou jusqu'à ce que la veilleuse reste allumée une fois que le bouton aura été relâché.
4. Tourner le bouton de contrôle du gaz jusqu'à la position "ON" (Marche).
5. Allumer l'interrupteur électrique si vous en utilisez un.

POUR ÉTEINDRE L'APPAREIL

1. Pour éteindre de façon temporaire: éteindre l'interrupteur électrique si vous en utilisez un, ou tourner le bouton de contrôle du gaz jusqu'à la position "PILOT" (Veilleuse). La veilleuse continuera de fonctionner. L'appareil est prêt à être remis en marche (position "ON").
2. Pour l'éteindre de façon durable, appuyer légèrement sur le bouton et le tourner jusqu'à la position "OFF".

HL14/BV-002BB